

# Avtron Brushless Tachometer BC42 and BC46 Upgrade

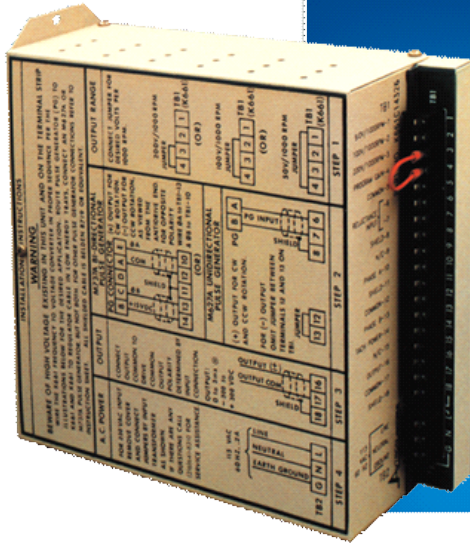

**Analog Tachogenerator Replacement: Frequency to DC High Voltage Converter**

## Easy, Maintenance Free Upgrade **K661**

- | Direct Replacement for All 5BC42, 5BC46 & 5BC66 Tachogenerators
  - | Severe Mill Duty
  - | Fits Existing Bolt Patterns
- | No Drive Configuration Changes Required
- | No Brushes, No Maintenance
  - | Better Speed Regulation
- | Self-Diagnostic LED and Alarm Output
  - | -40C\* to +120C\* Operation
  - | 1 Year No-Hassle Warranty

Replaces GE 5BC42/46/66 Analog Tachogenerators, NEMA 56C Face & Foot Mount

THE Avtron Brushless Upgrade Package with K661 and AV485 encoders replaces old, obsolete GE 5BC42, 5BC46 & 5BC66 analog tachogenerator models. It fits existing bolt patterns: both foot mount and existing motor flanges (NEMA 56C style). Other Avtron model encoders (AV850) are available to eliminate moving, wearing parts and motor flanges completely!

Using the Avtron update package, you will improve the output and speed control accuracy of your machine, while eliminating costly downtime.

Unlike low-quality converters, the Avtron solution is extremely linear and accurate, with no “gearshift” behaviors that can damage your product quality. The output is repeatable to 0.002%! The K661 offers 50V/1000RPM, 100V/1000RPM and 200V/1000RPM selections to replace all common tach styles.

The brushless upgrade package is simple to install: mount the K661 converter in your drive cabinet, route a new encoder-to-drive shielded twisted pair cable, and mount the Avtron AV485 encoder. There are no changes required to your existing drives.

Keep your analog drives working for years to come, improve reliability, and increase your machine output. Select the Avtron Brushless Upgrade Package today!

## OUTLINE DRAWING

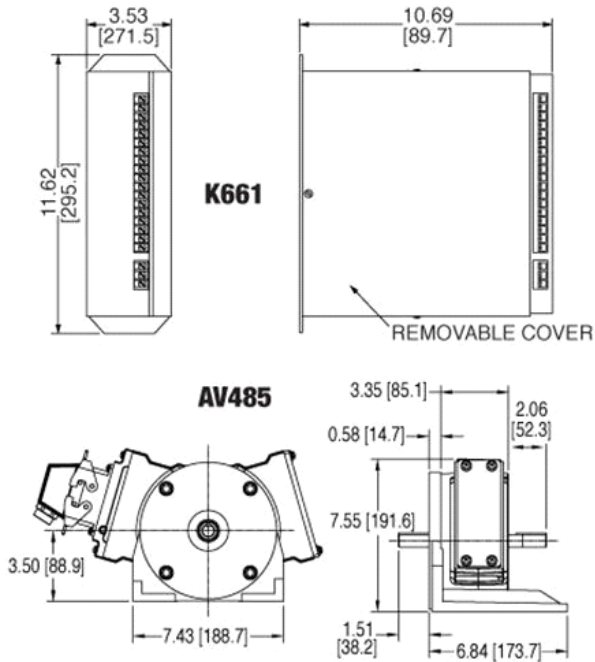

## MORE K661 ADVANTAGES

- SMARTach sensors find problems before they cause a failure
- Digital technology supports future digital drive upgrades
- Replacement and spare parts widely available & interchangeable with AV485, AV685, & AV850
- Optional winder/ultra-low-speed control
- Optional encoder air purge permitted for explosive atmosphere applications
- Alternate AV850 encoder can be used on many DC motors to eliminate couplings, bearings, and all wearing parts
- Optional shaft grounding or dual through-shaft for accessory mounting
- Additional options to replace GE PY & Baldor/Reliance RE210 models

## K661 SPECIFICATIONS

**Operating Power:** 110VAC, 0.25A

**Output Format:** 50, 100, or 200V/1000RPM

**Linearity:** +/-0.002%

**Offset:** None

**Reversing Error:** Zero

**Speed:** 5000 RPM Max. (contact factory for higher speeds)

**Temperature:**

- K661: 0°C to -60°C (for cabinet mount)
- AV485: -40°C\* to +120°C\* (for machine mount)
- AV850: -40°C to +100°C (for machine mount)

**Encoder Electronics:** Fully Encapsulated, IP67\*\*

**Vibration (encoder):** 18g's

**Shock (encoder):** 1 meter drop test

**Weight (encoder + converter):** 25lbs [11kg]

Check out our website for more detailed specifications, drawings, and installation instructions. [www.avtronencoders.com](http://www.avtronencoders.com)

\* AV485: -20C to +80C standard

\*\* Connector options may reduce IP rating

## SELECTION GUIDE

**Nidec**

**AVTRON  
ENCODERS**

Nidec-Avtron Makes the Most Reliable Encoders in the World

8901 E. PLEASANT VALLEY ROAD • INDEPENDENCE, OHIO 44131-5508

TELEPHONE: (1) 216-642-1230 • FAX: (1) 216-642-6037

E-MAIL: [tachs@nidec-avtron.com](mailto:tachs@nidec-avtron.com) • WEB: [www.avtronencoders.com](http://www.avtronencoders.com)

**CE**

All dimensions are in inches [millimeters].  
Specifications and features are subject to change without notice.  
EU-SMART™, SMARTSafe™, SMARTach II™, THIN-LINE™,  
THIN-LINE II™, WIDE-GAP™, and BULLSEYE32™ are trademarks  
of Nidec Avtron Automation. All other trademarks and registered  
trademarks are the property of their respective owners.